

## 20-Minute Fire-Rated Wood Frame

### Installation Instructions

#### NOTES:

**Door System Maximum Sizes** allowed with door slabs that are labeled for 20-minute fire ratings

- Single Door = 4'0" Wide x 9'0" High
- Double Door = 8'0" Wide x 9'0" High

#### Hinges

- Hinges must comply with NFPA 80
- Universal Industrial SOSS Hinge Models 218 and 418 are allowed with this frame for neutral pressure without hose stream ratings only (UL 10B and NFPA 252), for use in doors up to 8' high. Universal Industrial's listed installation instructions must be followed.

### STEP 1: FASTEN FRAME AND CASING (AT JAMBS AND HEADER) TO ROUGH OPENING

**Note:** The requirements on gap size between the back of jamb and header, and face of rough opening stud.

**Note:** Requirements on nail size, location and quantity.

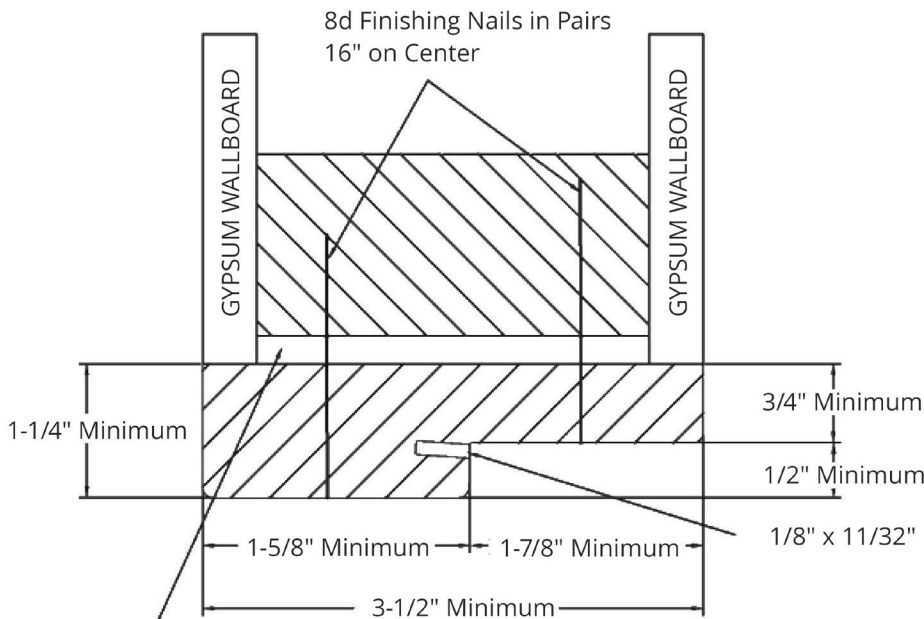

#### Clearance:

- Maximum gap of 1/4" without fiberglass insulation
- Maximum gap of 1/2" with fiberglass insulation (gypsum to gypsum with no voids)

**Note:** Applies to both jambs and header.

**Casing / Trim / Brickmould**

- Attach with 6d Finishing Nails, 16" On Center
- Required on interior and exterior sides of unit
- Pine (Solid or finger-jointed) or other wood of equal or greater density allowed.



# VICTORY

## MILLWORK

### STEP 2: PLACE SHIMS

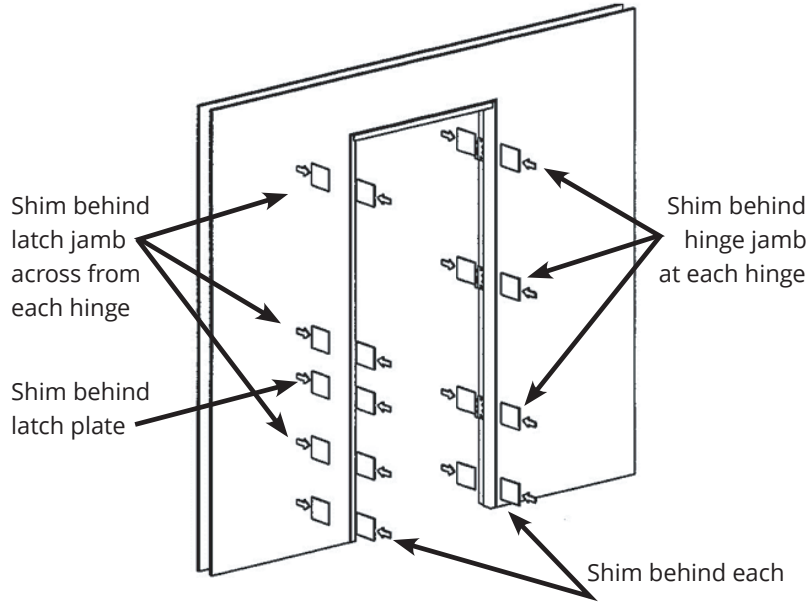

#### Hinge Screws - At each hinge use the following fasteners:

- (2) # 8 x 1-1/4" wood screws - place in holes closest to edge of jamb
- (2) # 12 x 2-1/2" wood screws - place in holes closest to center of jamb

#### Latch Plate Screws - Use the following fasteners:

- (2) # 8 x 2-1/2" wood screws

### STEP 3: SECURE SHIMS

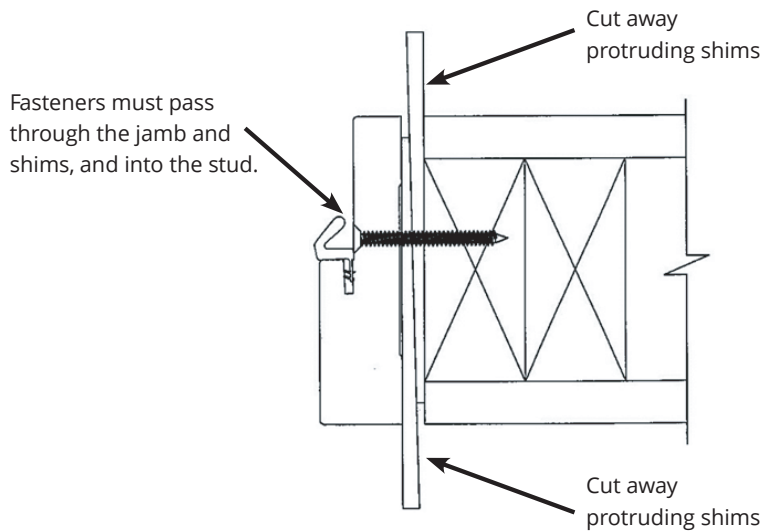

#### Notes:

- Drawing shows single rabbet. Double rabbet is allowed.
- Jamb extensions can be installed on the jambs and header. Extensions must be wood of same or higher density as header.
- Jambs and header may be wrapped in wood veneer, vinyl film or HPL.

### ADDITIONAL NOTES:

- Trimming for height may be done on the bottom rail only (per NFPA 80, maximum trim of 3/4"/19.0 mm allowed on site).
- Trimming for height is not allowed for Steel Doors.
- Surface mounted hardware must be attached with through bolts unless interior blocking is provided.
- A maximum 1/8" (3.2 mm) clearance between the frame and door is allowed.
- A maximum 1/8" (3.2 mm) clearance between the top leaf and the bottom leaf of dutch door, or transom and door, or between leaves of pairs, is allowed.